

Figure 2: 629HLP-3V P/T ports

Then, using the P/T ports (see Figure 2), bleed the lines one side at a time until the flowing liquid is free of bubbles. Once the system is bled, open valve V3. Then, slowly close valve V1. This will establish differential pressure across the device.

When removing the transmitter with valve assembly from operation, first open valve V1, then close valves V2 and V3. Then, bleed off trapped pressure using either of the P/T ports.

Alternate Valve Assembly

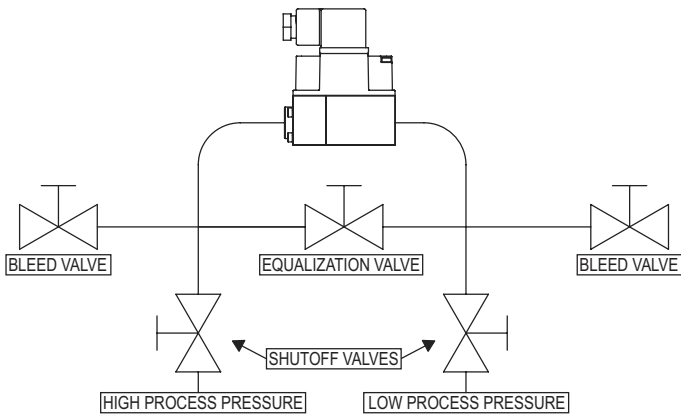

Figure 3

To install the 629HLP without the available 3-way valve option, it is recommended that the unit be connected in the configuration above (Figure 3). Begin with the equalization valve open and all other valves closed. Then, slowly open the high pressure valve - the same pressure will apply to both sides of the device. Then bleed the lines one side at a time until the flowing liquid is free of bubbles. Once the system is bled, open the low pressure valve. Then, slowly close the equalization valve. This will establish differential pressure across the device.

When removing the transmitter with valve assembly from operation, first open the equalization valve, then close the high and low pressure valves. Then, bleed off trapped pressure.

Electrical Connections

CAUTION This unit is not designed for 120 or 240 VAC line operation. Do not exceed specified supply voltage rating. Permanent damage not covered by warranty may result.

To make the electrical connections to the transmitters remove the top screw and lift the connector housing (Figure 4). The terminal block is located inside (Figure 5).



Figure 4



Figure 5

Terminal Wiring

Wire as shown in Figure 6a or Figure 6b depending on the output signal required.

WIRING - VOLTAGE OUTPUT

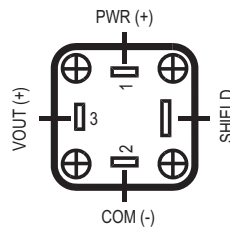

Figure 6a (0-10 VDC)

WIRING - CURRENT OUTPUT

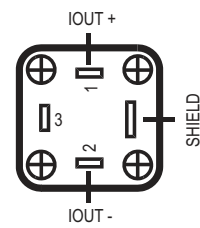

Figure 6b (4-20 mA)

Note: Shielded cable is required. Cut the shield wire at the power supply end of the cable.

Wire Length: The maximum length of wire connecting the transmitter and receiver is a function of wire size and receiver resistance. Wiring should not contribute more than 10% of the receiver resistance to total loop resistance. For extremely long runs (over 1000 feet), choose receivers with lower resistance to minimize the size and cost of connecting leads. Where wiring length is under 100 feet, wire as small as 22 AWG can be used.

MAINTENANCE/REPAIR

Upon final installation of the 629HLP, no routine maintenance is required. The 629HLP is not field serviceable and it is not possible to repair the unit. Field repair should not be attempted as this may violate the warranty.

WARRANTY/RETURN

Refer to "Terms and Conditions of Sale" in our catalog and on our website. Contact customer service to receive a Return Goods Authorization number before shipping the product back for repair. Be sure to include a brief description of the problem plus any additional application notes.

USA: California Proposition 65
 ⚠️WARNING: Cancer and Reproductive Harm - www.P65Warnings.ca.gov



Series 629HLP Differential Pressure Transmitters

Specifications - Installation and Operating Instructions

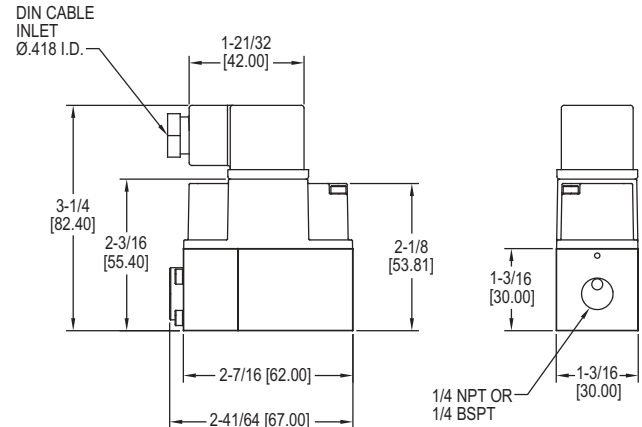
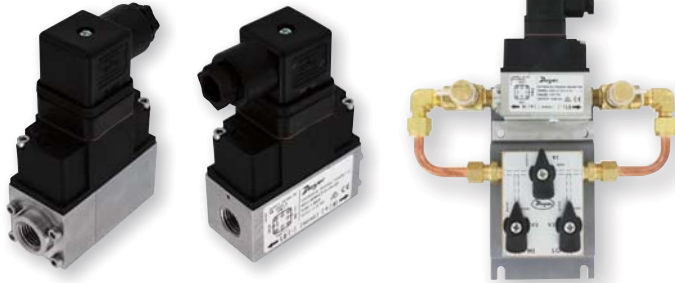

The **Series 629HLP Differential Pressure Transmitters** are suitable for measuring over-pressure, under-pressure, and differential pressure in compatible gases and liquids with 1% accuracy. The 629HLP is suitable for all measuring tasks in commercial, industrial or sanitary applications. Its single diaphragm design, allows it to measure small increment pressure changes, and converts them to a linear analog output signal from 4-20 mA or 0-10 VDC.

Installation Location/Mounting

The transmitter can be mounted in various locations as long it is not subject to excessive vibration, shock, or extreme temperature (see specifications). The tubing feeding the pressure port may be of any length, but longer lengths will increase the response time slightly. Avoid sharp bends, and depending on the vibration and shock it is recommended to install attenuating components.

To facilitate installation, mounting bracket A-629HLP-BKT, is available as accessory.

Position/Orientation

The transmitter is not sensitive to installation position. However, factory calibration is performed with the unit in a vertical position and horizontal pressure connections.

Pressure Connections

Pressure connections to the 629HLP unit are 1/4" female NPT or 1/4" female BSPT. Avoid excess sealant and ensure the pressure passages are not blocked.

For the optional 3-way valve, pressure connections are 1/8" female NPT or 1/8" female BSPT (using included adapters).

The fitting assembly being connected should allow removal and reinstallation of the transmitter without shutdown of the pressure system, and allow balancing of the low and high side pressures. This is especially important in applications where the differential pressure is measured from high static line pressures that, if applied separately, exceed the maximum differential over pressure of the transmitter. Dwyer offers a 3-way valve manifold option for this purpose (See Figure 1). Alternatively, a 3-way valve manifold with bleed valves can be used.

Optional 3-Way Valve

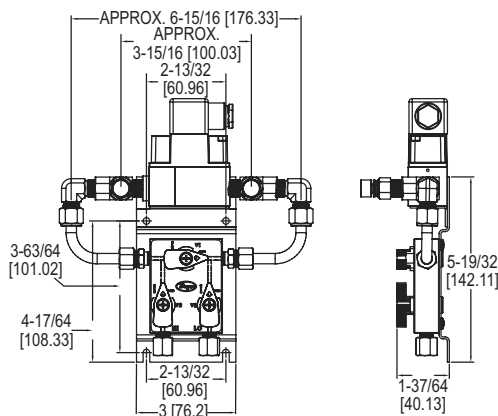

Figure 1

To install the 629HLP with 3-way valve assembly (Figure 1) into the system, begin with valve V1 open and valves V2 and V3 closed. Install the pressure supply to the high and low inlets at the bottom of the valve. Once lines are installed, slowly open valve V2 - the same pressure will apply to both sides of the device.

SPECIFICATIONS

Service: Compatible gases or liquids.
Wetted Material: 304 SS, EPDM, silicone grease, alumina ceramic; Optional 3-way valve: brass, copper, nylon, HNBR, FKM, NBR.
Housing Material: ABS.
Enclosure Rating: IP65.
Accuracy: ±1% from -5 to 60°C (23 to 140°F).
Stability: ±1% FS/year.
Temperature Limits: Ambient: -10 to 60°C (14 to 122°F); Process: -10 to 80°C (14 to 176°F).
Relative Humidity: 10% to 90% non-condensing.
Installation Position: Not position sensitive.
Pressure Limits: See Pressure Range Limits chart.
Burst Pressure: See Pressure Range Limits chart.
Static Pressure Limits: See Pressure Range Limits chart.
Output Signal: 4-20 mA, 0-10 VDC.
Response Time: 50 ms.
Rated Supply Voltage: 0-10 VDC Output: 12-36 VDC or 12-32 VAC (@ Max load of 2k Ω) 4-20 mA output: 8-36 VDC.
Max Loop resistance: (Supply Voltage – 8 V) / 0.02 for 4-20 mA output.
Power Consumption: $V_{out} = 13 \text{ mA max}$, $I_{out} = 24 \text{ mA max}$.
Electrical Connections: Form A DIN 43650.
Process Connections: Standard: 1/4" female NPT, 1/4" female BSPT. With 3-way valve option: 1/8" female NPT, 1/8" female BSPT.
Weight: 1 lb 4 oz (567 g).
Approvals: CE, RCM.

MODEL CHART

Example	629HLP	-01	-P2	-S1	-FC	629HLP-01-P2-S1-FC
Series	629HLP					Differential pressure transmitter
Range		01 02 04 06 15 30 60 90				0 to 1 bar 0 to 2.5 bar 0 to 4 bar 0 to 6 bar 0 to 15 psi 0 to 30 psi 0 to 60 psi 0 to 90 psi
Process Connections			P2 P4			1/4" female NPT 1/4" female BSPT
Output Signal				S1 S5		4-20 mA 0-10 VDC
Options					FC NIST 3V	Factory calibration NIST certificate 3-way valve

Note: PSI ranges available upon request. Contact factory for details.

PRESSURE RANGE LIMITS

Pressure Range	Maximum Static Pressure	*Maximum Differential Over Pressure	**Burst Differential Pressure
0 to 1 bar	25 bar	5 bar	8 bar
0 to 2.5 bar	25 bar	5 bar	8 bar
0 to 4 bar	25 bar	12 bar	18 bar
0 to 6 bar	25 bar	12 bar	18 bar
0 to 15 psi	360 psi	70 psi	115 psi
0 to 30 psi	360 psi	70 psi	115 psi
0 to 60 psi	360 psi	174 psi	260 psi
0 to 90 psi	360 psi	174 psi	260 psi

Note: *The differential pressure limit, between high and low ports, that the transmitter can withstand without affecting transmitter performance
 **Differential pressures between high and low ports that exceed overpressure limits will result in permanent diaphragm deformation, and any pressure higher than the burst pressure limits will rupture the diaphragm.